

Highway tow 600 litre and 800 litre water bowser, mounted on single axle chassis, with petrol/diesel engine and pump combinations, capable of producing up to 15 lpm max flow 207bar max pressure. Complete with a 30m high pressure hose reel and hose.

Bowser Specifications

- Durable and corrosion resistant polyethylene tank, baffled for safe transport of water
- Heavy duty hot-dipped galvanised steel chassis, fully approved for towing on highways
- Adjustable jockey wheel and ball coupling (eye coupling option on request)
- Mudguards, 13-pin plug and highway lighting to EU specifications
- Two rear lights housed in a steel channel for protection
- Fitted with rubber suspension, auto-reverse braking and hand parking brake
- Interpump series plunger pump and gearbox, with 200Bar max pressure and 15LPM max flow ratings, capable of powering accessories such as rotary hard surface cleaners and water brooms, etc.
- Reliable Honda GX390 petrol engine, for easy start and smooth, powerful performance, mounted on to the galvanised chassis
- Unloader valve with internal bypass, ensures longevity of the pump seals
- Inline suction filter, to prevent any muck from entering the pump
- Chemical injector valve with line and filter for applying detergents
- Pedestal mounted heavy duty lockable metal hose reel with 30-metres of twin-wire high pressure hose, 36inch dual lance and 1/4" MEG fan nozzle
- Assortment of 5 different nozzles, 15deg, 25deg, 40deg, pencil and foaming tips – for every eventuality

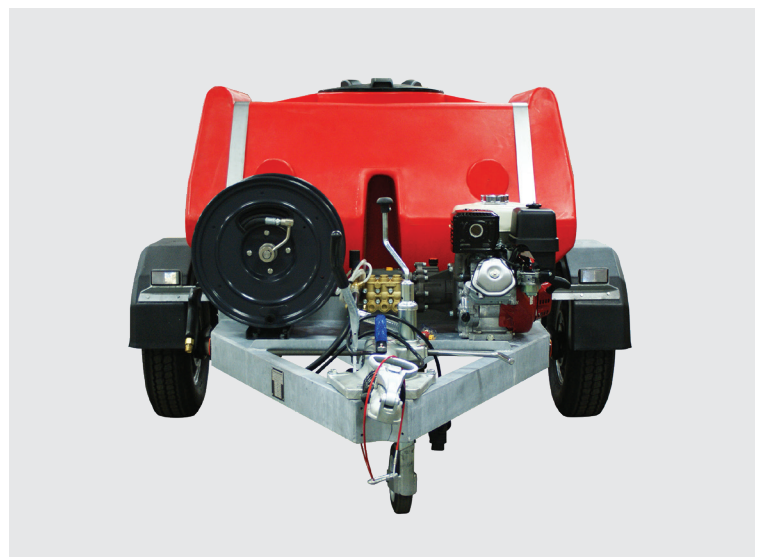
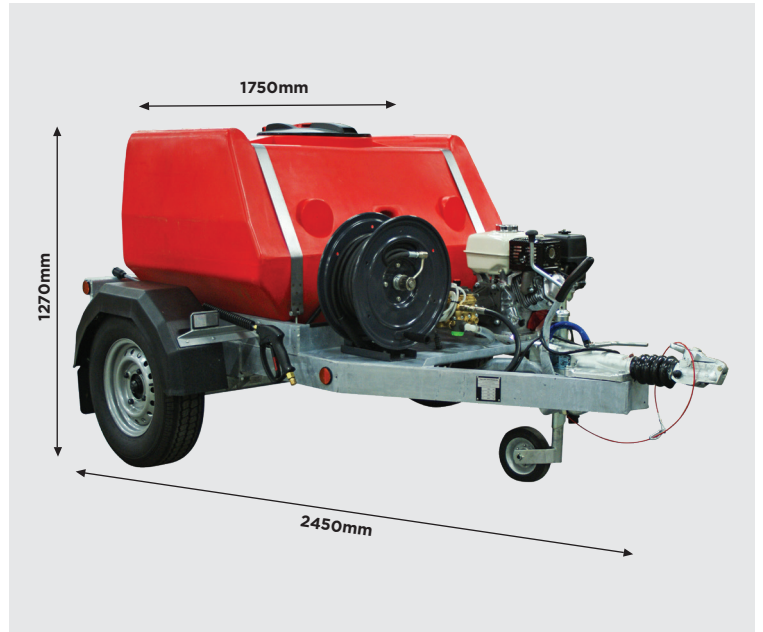

Specifications	
Tank Sizes	600L / 800L
Max Rated Pressure	200bar (2,900psi)
Max Rated Flow	15LPM (3.95 GPM)
Max Rated Temp	60°C / 140°F